

NISSAN DIESEL AMERICA, INC.

BODY BUILDER'S BOOK BULLETIN

DATE: OCTOBER 21, 2004
MODEL YEAR: 2005 AND AFTER
CHASSIS MODEL: UD1800CS ~ UD3300
BULLETIN NUMBER: BBB-9

2005 MODEL YEAR AND AFTER UD1800CS ~ UD3300 VAN BODY INTERIOR LIGHT CONNECTION

PURPOSE

To announce the addition of a dedicated van body interior light connector at the rear of the left chassis frame rail.

RECOMMENDATION

It is recommended that van body interior work lights be connected to this protected circuit that is activated through the ignition circuit.

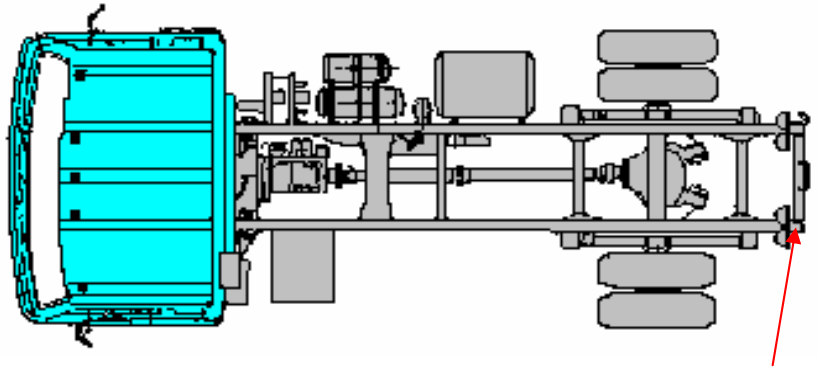

NEW VAN BODY INTERIOR LIGHT CONNECTOR AT LEFT REAR OF FRAME IS IDENTIFIED WITH A TAG LABELED "R"

BODY INTERIOR LIGHT CIRCUIT

The van body interior light circuit is energized by Accessory Relay #1 via the Number 3 (10 amp) fuse in the fuse box. The relay is energized when the ignition switch is in the "ON" or "ACC" positions.

Van body interior lights should never be connected to any other electrical circuit in the vehicle except the van body interior light connector. This circuit is designed for "standard" van body interior lights not to exceed the maximum allowable amperage load described in the table below.

VAN BODY INTERIOR LIGHT CIRCUIT		
MODEL	MAXIMUM ALLOWABLE AMPERAGE LOAD	WIRE COLOR, LEFT REAR OF FRAME
UD1800CS	48 WATTS (12 VOLTS @ 4 AMPS)	RED (CONNECTOR T10)
UD1800HD ~ UD3300	48 WATTS (12 VOLTS @ 4 AMPS)	RED (CONNECTOR T10)

THE INFORMATION CONTAINED IN THIS BULLETIN SHOULD NOT BE INTERPRETED AS THE BASIS FOR WARRANTY CLAIMS UNLESS SO DESIGNATED