



TECHNICAL BULLETIN

Nissan Diesel America, Inc
P.O. Box 152034, Irving, Texas 75015

***BEGINNING SERIAL NUMBER:
FE6TA - 105884**

**DATE: FEBRUARY 28, 1994
MODEL YEAR: ALL
ENGINE MODEL: FE6, (T), (TA)
BULLETIN #: EN - 17
FILE IN ENGINE SECTION**

FE6, FE6T, FE6TA CONNECTING ROD

PURPOSE:

*This service advisory is to remind the UD Truck Dealer that a new, "heavier" connecting rod for the FE6TA was introduced with the November 1992 production models beginning with the engine serial number described above.

With the introduction of the new connecting rod, part number 12100 - Z5502, two connecting rods are now available for the FE6 engine family.

FORMER CONNECTING ROD 12100 - Z5501	NEW CONNECTING ROD 12100 - Z5502
FE6 (non-turbo) FE6T (turbocharged) FE6TA - 105883 and previous	*FE6TA - 105884 and after

The new version connecting rod requires a higher torque specification for tightening the connecting rod bolt and nut.

SERVICE NOTICE:

The new connecting rod is heavier in appearance from the former connecting rod. Positive identification between the former version and the new version is obtained by means of the casting symbols found on the stem of the connecting rod.

The casting symbol on the former version, part number 12100 - Z5501, is "E00".
The casting symbol on the new version, part number 12100 - Z5502, is "00".

Additionally, the new version connecting rod utilizes knurled connecting rod bolt stems. The former version connecting rod utilizes shouldered connecting rod bolts.

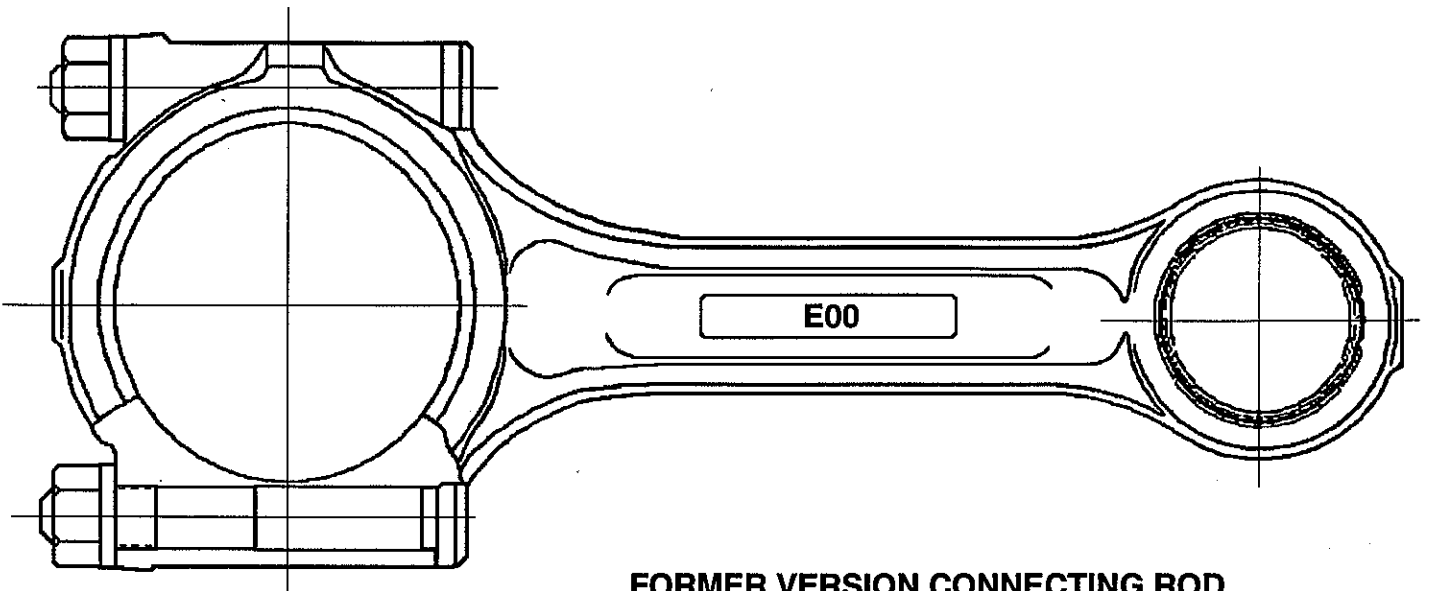

**FORMER VERSION CONNECTING ROD
PART NUMBER 12100 - Z5501**

NOTE: When replacing connecting rods, always position the connecting rod such that the casting symbol faces the front of the engine, and then stamp the cylinder number on the left side (driver's side) of the connecting rod and connecting rod cap.

KNURLED SECTION OF CONNECTING ROD BOLT

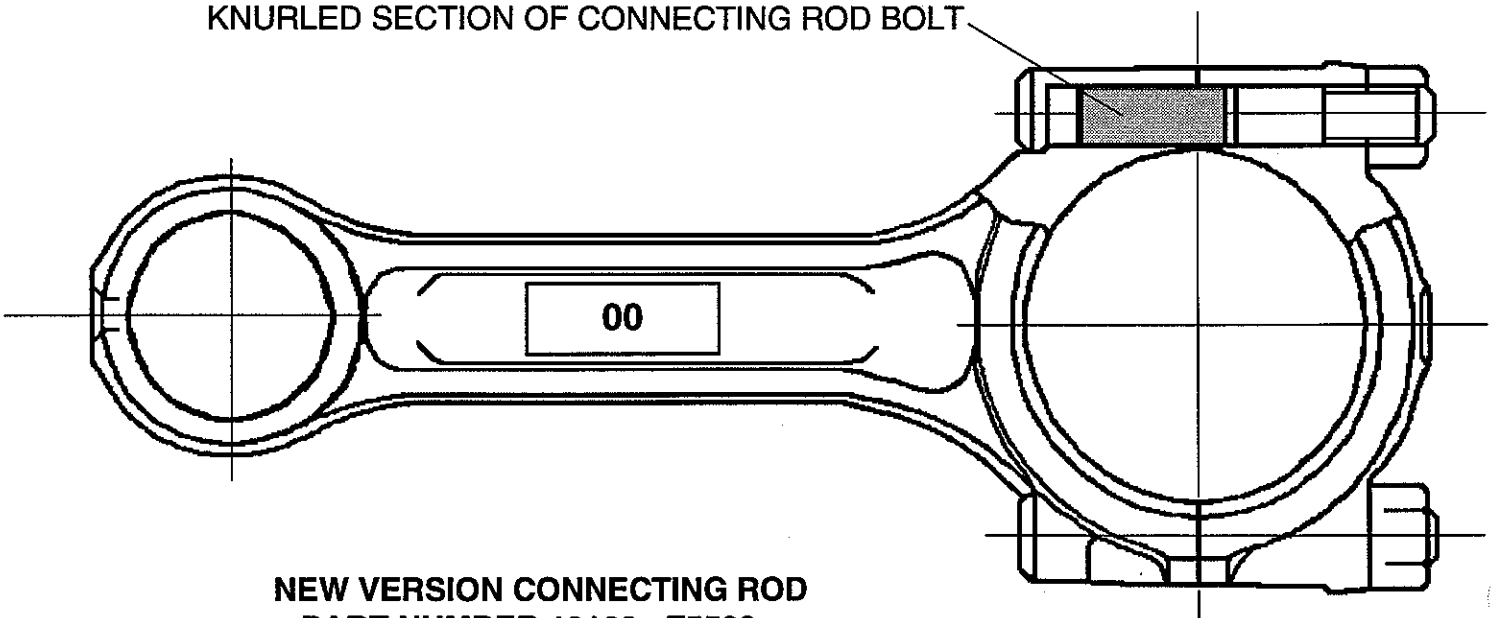

**NEW VERSION CONNECTING ROD
PART NUMBER 12100 - Z5502**

CONNECTING ROD TIGHTENING TORQUE

FORMER VERSION

12100 - Z5501
83 - 87 ft·lbs
(11.5 - 12.0 kg·m)

NEW VERSION

12100 - Z5502
98 - 105 ft·lbs.
(13.5 - 14.5 kg·m)

Interchangeability: Conditional

YES Only as a complete set can the new version connecting rod (12100 - Z5502) be used in the FE6 and FE6T engines.

NO Due to the heavier weight of the new version connecting rod (12100 - Z5502), individual connecting rods should not be intermixed with the former version connecting rods (12100 - Z5501) in any engine.

NO Do not install former version connecting rods (12100 - Z5501) in FE6TA engines with serial number 105884 and later.

The information contained in this bulletin should not be interpreted as the basis for claims unless so designated.