

# Quon

CW 26 400 | 460  
6x4 Rigid



## QUON UNIQUE FEATURES

### SPECIFICATIONS

<b>Power:</b>	GH11TB - 294 kW (400 PS) @ 1600 rpm GH11TD - 338 kW (460 PS) @ 1600 rpm
<b>Torque:</b>	GH11TB - 2000 Nm (1475 lb.ft) @ 950 rpm GH11TD - 2250 Nm (1659 lb.ft) @ 1000 rpm
<b>Transmission:</b>	ESCOT-VII automated manual transmission (AMT)
<b>Suspension:</b>	Leaf spring or electronically controlled air suspension
<b>Wheelbase:</b>	Refer weights and dimensions table
<b>GVM:</b>	26,000 kg
<b>GCM:</b>	50,000 kg (400hp) 60,000 kg (460hp)



#### NEW SMART FUEL EFFICIENT ENGINES WITH RESPECT FOR THE ENVIRONMENT

GH11 engine: fuel efficient, powerful and clean



#### SMART UPTIME

Quon has been designed to further optimise uptime, with superior reliability and increased maintenance intervals.



#### SMART SAFETY

Active safety with mechanical and electronic features throughout, including safety for vulnerable road users.



#### SMART PRODUCTIVITY

Light weight chassis helping to maximise payload. New engines with improved horsepower and torque to increase productivity.



#### SMART DRIVABILITY

The cabin has been designed with the user's comfort in mind, with outstanding ergonomics and visibility allowing the driver to concentrate on driving

# GENERAL SPECIFICATIONS

## SAFETY

- Passive Safety:**
- Highly rigid cabin with ECE R29 rating
  - Side door beams
  - Front underrun protection system (FUPS)
  - SRS driver steering wheel airbag
  - Driver side seat belt with pre-tensioner
  - Steering wheel & column with impact absorption function

- Active Safety:**
- Traffic Eye Brake System (AEB)
  - Traffic Eye Cruise Control with auto stop & go
  - Traffic sign recognition
  - Lane departure warning system
  - Electronic stability control
  - Automatic hill start assist (ESCOT VI)
  - Lane change support LHS & RHS
  - Blind spot information system LHS & RHS
  - Vulnerable road user detection LHS, RHS & front.

- Basic Safety:**
- LED Headlamps (low beam only)
  - Disc brakes
  - Anti Locking Brake System
  - Emergency Braking System
  - UD Extra Engine Braking (UD EEB)
  - Safe Brake Blending
  - Immobiliser
  - Two-step entry and exit

## ENGINE

<b>Model:</b>	GH11TB   GH11TD
<b>Description:</b>	6 cylinder, 4 stroke diesel engine
<b>Displacement:</b>	10,837 cc
<b>Bore x stroke:</b>	123 mm x 152 mm
<b>Compression ratio:</b>	17.5:1
<b>Max. governed engine speed:</b>	2,100 rpm

**GH11TB400PS**  
294kW (400PS) @ 1,600rpm  
2,000Nm (1475 lb-ft)  
@ 950 -1,350rpm

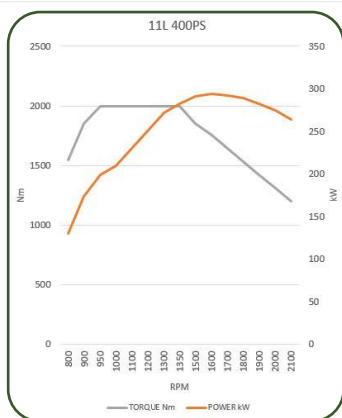

**GH11TD460PS**  
338KW(460PS) @ 1,600rpm  
2,250Nm (1659 lb-ft)  
@ 1,000 - 1,200rpm

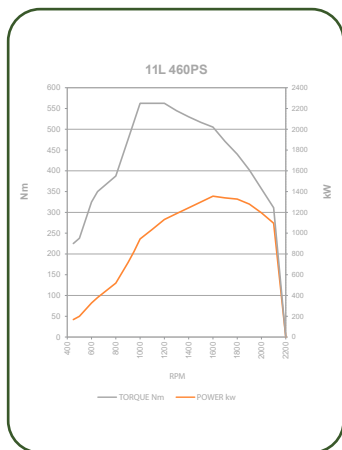

## FUEL AND INTAKE SYSTEM

<b>Fuel capacity:</b>	400 litres
<b>Injection type:</b>	High pressure common rail direct fuel injection system
<b>Filtration:</b>	Chassis mounted primary filter and engine mounted secondary filter

## EMISSION CONTROL

<b>Emission standard:</b>	pPNLT (equivalent to Euro 6 emission requirements)
<b>Adblue capacity:</b>	50 litres
<b>Exhaust system:</b>	RHS chassis mounted box muffler

## ELECTRICAL

<b>Power:</b>	24 volt, negative ground system
<b>Battery capacity:</b>	2 x 12 volt 165 Ah batteries
<b>Alternator:</b>	150 amp

## TRANSMISSION

<b>Make:</b>	UD Trucks
<b>Model:</b>	ESCOT-VII (ATO2612)
<b>Description:</b>	Automated manual transmission (AMT) 12 forward & 2 reverse gears
<b>Shift type:</b>	Electronic shifter with fully automatic or manual control

Gear ratios	1 <sup>st</sup>	11.73	7 <sup>th</sup>	2.70
	2 <sup>nd</sup>	9.21	8 <sup>th</sup>	2.12
3 <sup>rd</sup>	7.09	9 <sup>th</sup>	1.63	
4 <sup>th</sup>	5.57	10 <sup>th</sup>	1.28	
5 <sup>th</sup>	4.35	11 <sup>th</sup>	1.00	
6 <sup>th</sup>	3.41	12 <sup>th</sup>	0.78	
Rev 1	13.73	Rev 2	10.78	

<b>PTO capability:</b>	500 Nm @ 103% or 81% (PTR-FH6) 1000 Nm @ 115% or 90% (PTR-D)
------------------------	---

## FRONT AXLE AND SUSPENSION SYSTEM

<b>Ground capacity:</b>	8,200 kg
<b>Axle type:</b>	Reverse Elliot I-Beam
<b>Suspension:</b>	Parabolic leaf spring with double acting shock absorbers
<b>Spring dimensions:</b>	90mm x 1460mm
<b>Spring constant:</b>	347.7 N/mm

## REAR AXLE AND SUSPENSION SYSTEM

<b>Ground capacity:</b>	20,000 kg
<b>Axle type / model:</b>	Single reduction, hypoid gear, with cross locks
<b>Final reduction ratio:</b>	4.13, 4.50
<b>AIR SUSPENSION</b>	
<b>Description:</b>	8 air bag
<b>Shock absorbers:</b>	Telescopic double acting
<b>Road friendly certification number:</b>	RF2099 (air only)
<b>Control system:</b>	Electronic Controlled Air Suspension with remote control mounted in cab (ECAS4)

BRAKES	
<b>Type:</b>	Electronic braking system (EBS) with disc brakes on all axles
<b>Front/Rear:</b>	430 mm rotors / 430 mm rotors
<b>Park brakes:</b>	Hand-operated pneumatic spring park brake on drive axles
<b>Auxiliary brake:</b>	Exhaust plus engine compression type (EEB)
<b>Trailer connections:</b>	Air and electrical connections to rear of chassis

STEERING	
<b>Type:</b>	Recirculating ball and screw with hydraulic assist
<b>Steering gear ratio:</b>	24.1 - 26.8 : 1
<b>Column:</b>	Adjustable, tilt and telescopic control
<b>Steering wheel:</b>	460 mm diameter with ignition key steering lock

WHEELS & TYRES	
<b>Wheels:</b>	8.25in x 22.5in rim with 165mm offset and ISO 10 stud pattern (335mm PCD)
<b>Front tyres:</b>	295/80 R22.5 Bridgestone R150Z
<b>Rear tyres:</b>	11R 22.5 Bridgestone M711AZ
<b>Spare tyre</b>	295/80 R22.5 Bridgestone R150Z

FRAME	
<b>Width:</b>	850 mm
<b>Side rail dimensions:</b>	300 mm x 90 mm x 8 mm
<b>Material:</b>	Rolled high tensile carbon steel
<b>Tensile strength:</b>	600MPa / 600N/mm <sup>2</sup>

DRIVER INFORMATION & CUSTOMISABLE COLOUR DISPLAY SCREEN	
<b>In Dash Warning Systems:</b>	Visual warning lamps with audible warning tones, plus written warnings displayed in full colour on the information screen
<b>In Dash Driver Information:</b>	Customisable live information includes: On board fuel coaching with economy tips, fuel & AdBlue usage, instant fuel consumption, digital speedo, trip computer including: time, distance & distance to empty. Hour meter, coolant temp, engine oil temp, transmission oil temp, UDPC level and volt meter.

INTERNAL CABIN	
<b>Lighting:</b>	Dual ON/OFF/DOOR interior lights Interior neon cabin lamp
<b>Seating capacity:</b>	Two (three seats optional)
<b>Driver's seat:</b>	ISRI 6860/875 air suspended seat with integrated seat belt & adjustable arm rest. Adjustable height control & rebound damper. With split seat back adjustments for recline & head rest position. Seat base tilt, seat cushion slide, seat air dump switch. Adjustable air bladders (4) for side bolsters, upper & lower lumbar.
<b>Passenger seat/s:</b>	Assistant seat with adjustable back & head rest
<b>Sleeping capability:</b>	ADR 42/04 compliant sleeper bunk with mattress and full curtains
<b>Side windows:</b>	Power operated door glass
<b>Security:</b>	Remote central locking with immobiliser
<b>Air conditioning:</b>	Fully automatic climate controlled air conditioning with recirculation filter

<b>Multimedia unit:</b>	<ul style="list-style-type: none"> <li>▫ 8-inch touch screen</li> <li>▫ Hands-free Bluetooth operation.</li> <li>▫ FM1, FM2, FM3, AM, DAB+ tuner</li> <li>▫ USB input</li> <li>▫ Up to 5 cameras input</li> <li>▫ Wi-Fi Module</li> <li>▫ Phone tethering</li> <li>▫ Cordless Apple Car Play &amp; Android Auto</li> <li>▫ Truck specific satellite navigation</li> <li>▫ OTA (over the air updates)</li> </ul>
<b>Storage:</b>	Multiple in-cab compartments
<b>Power Outlet:</b>	24 volt 240W & 12 volt 120W in dash
<b>DIN accessory fitment:</b>	Two DIN sized compartments
<b>Floor covering</b>	Vinyl

EXTERNAL CABIN	
<b>Cab Description:</b>	Forward control, pressed steel construction
<b>Mounting type:</b>	Full floating, 4 bag air suspended cab with 4 dual acting shock absorbers and dual automatic height control valves.
<b>Cab paint:</b>	Standard – Polar White. Paint code W33
<b>Inspection points:</b>	Back of the cab and front panel
<b>Bumper type:</b>	3 piece with steel corner panels
<b>Mirrors:</b>	Heated and electrically operated main mirrors with flat glass, wide vision and passenger-side downward facing spot mirrors
<b>Lamps:</b>	<ul style="list-style-type: none"> <li>▫ LED head lamps (low beam)</li> <li>▫ Bumper mounted fog lamps</li> <li>▫ Roof mounted clearance lights</li> </ul>
<b>Wipers:</b>	Triple arm, 2 speed wipers with variable intermittent operation and integrated washers
<b>Reversing system:</b>	Reverse beeper and digital infrared camera with microphone

FACTORY OPTIONAL EQUIPMENT	
<b>Tyres:</b>	275 /70 R22.5
<b>Wheels:</b>	Alcoa aluminium wheels
<b>Rear engine PTO:</b>	D I N 5462 or Flange SAE1410; 650 Nm capacity
<b>Safety:</b>	<ul style="list-style-type: none"> <li>▫ Driver Alert System</li> <li>▫ Driver Monitoring System</li> </ul>
<b>Cab Interior:</b>	Leather steering wheel, woodgrain dash, centre console or 2nd passenger seat
<b>Cab Exterior:</b>	Roof scoop, chrome grille, roof beacon prep kit, bumper spoiler, passenger door peep window, cab auxilliary side windows
<b>Additional Wheelbases:</b>	4,250mm, 4,700mm & 5,100mm
<b>Chassis:</b>	Additional 400 litre fuel tank (V wheelbase only), front axle stabiliser.
<b>Cab Paint:</b>	Custom paint colours.

UD CONNECT (FLEET MANAGEMENT)	
<b>Telematics hardware:</b>	In-cab GSM and GPS unit with SIMcard connected to roof antenna
<b>Subscription:</b>	12 months included
<b>Key Reports:</b>	<ul style="list-style-type: none"> <li>▫ Total operational time and distance</li> <li>▫ Average speed and fuel consumption</li> <li>▫ Total CO2 emission</li> <li>▫ Vehicle utilisation</li> <li>▫ Anticipating &amp; braking</li> <li>▫ Engine &amp; gear utilisation</li> <li>▫ Speed adaptation</li> <li>▫ Time idling (standstill)</li> </ul>

## MAJOR DIMENSIONS

Mass (kg)					i) 400hp Vehicle Dimensions (mm)															
Variant	Wheelbase code	GCM*	GCM	Total Tare	WB	TWB	OL	OW	OH	FT	RT	AS	ROH	RFL	CA	GC	FHF	FHR	Turning radius (kerb to kerb)	UD order code
UD - Leaf	L	26000	50000	7830	3700	4385	7867	2490	2970	2062	1851	1370	1960	2645	2985	249	1022	1091	6900	CW26400LAL
	T	26000	50000	8063	5350	6035	11167	2490	2970	2062	1851	1370	3610	4295	4635	249	1026	1089	9300	CW26400TAL
UD - Air	V	26000	50000	7956	5800	6485	11467	2490	2970	2062	1851	1370	3410	4095	5085	249	1027	1028	9900	CW26400VAA

Mass (kg)						ii) 460hp Vehicle Dimensions (mm)																
Variant	Wheelbase code	GCM*	GCM	Front Tare	Rear Tare	Total Tare	WB	TWB	OL	OW	OH	FT	RT	AS	ROH	RFL	CA	GC	FHF	FHR	Turning radius (kerb to kerb)	UD order code
UD - Leaf	K	26000	60000	4374	3492	7866	3600	4285	7557	2490	2970	2062	1851	1370	2060	2745	2745	249	1030	1038	6800	CW26460KAL
		26000	60000	4379	3453	7832	3600	4285	7557	2490	2970	2062	1851	1370	2060	2745	2745	249	1027	1091	6800	CW26460KAA

\*Rated GVM and axle capacities are subject to Federal, State and Territory legal requirements.

Mass is an estimation based only on standard model, includes fluids (no diesel fuel or Adblue®). Excludes spare wheel. Excludes driver and tools. Subject to ± 3% tolerance.

Ground clearance is based on vehicle with standard wheels and tyres. For alloy rims deduct 28kg from Front tare and deduct 56kg from each rear axle in rear tare.

For alloy rims add 18mm to both FT and RT measurements

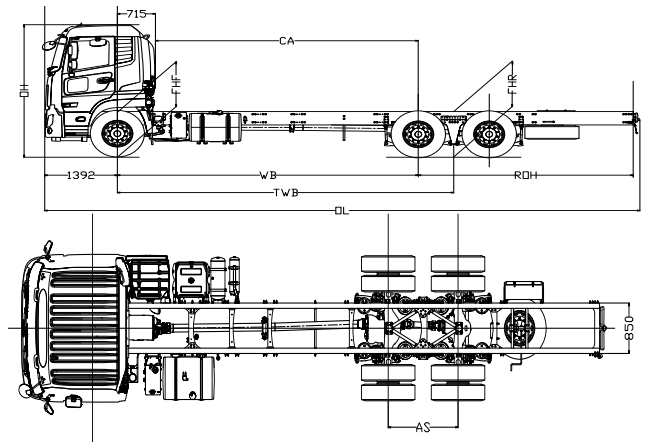
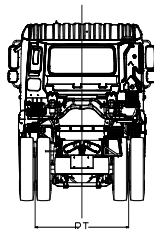

## WARRANTY

<b>Standard warranty*</b>	36 months/500,000 kms
<b>Cab corrosion warranty*</b>	36 months/unlimited kms

+ For details refer to your UD Trucks New Vehicle Warranty brochure  
 ++ Purchased by the owner and covers selected factory items only.  
 For details refer to your UD Trucks New Vehicle Warranty brochure