



TECHNICAL BULLETIN TR-14 (REV.)

DATE: MARCH 21, 2001
MODEL YEAR: 1995 AND AFTER
CHASSIS MODEL: UD1800HD ~ UD3000
TRANS. MODEL: MLS61B
BULLETIN #: TR - 14 (Revised to include synchronizer kit part numbers)
FILE IN THE TRANSMISSION SECTION OF THE TECHNICAL BULLETIN BINDER

MLS61B TRANSMISSION SYNCHRONIZER PART NUMBER CHANGES

PURPOSE

To notify the UD Dealer Service Managers, Parts Managers and UD Truck Technicians that the 3rd ~ 4th and 5th ~ 6th gear synchronizer part numbers have changed in the MLS61B manual transmission beginning with the 1999 model year VINs listed below. This bulletin also provides the part number change information.

UD1800HD	JNAMA33H3XGH50047
UD2000	JNAMB33H5XGF50025
UD2300	JNALC33H9XGF50022
UD2600	JNAPA33H9XGL50021
UD3000	JNAPB33H5XGN50018

SERVICE NOTICE

The baulk angles of the 3rd ~ 4th and 5th ~ 6th gear synchronizer rings and sleeves have changed as illustrated below.

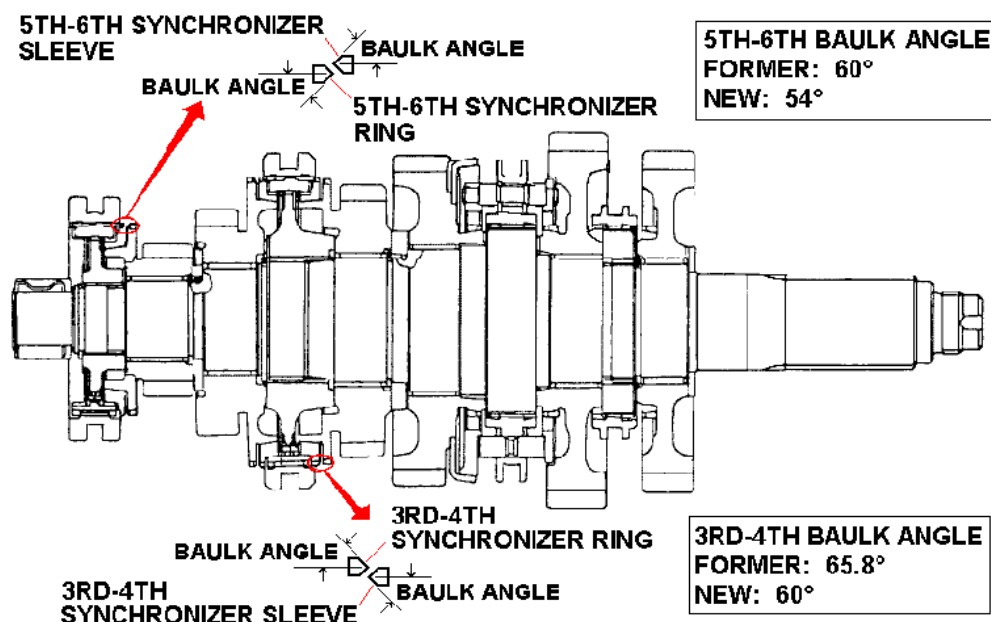

These synchronizers should be used when replacing the 3rd ~ 4th and 5th ~ 6th gear synchronizers in MLS61B transmissions in 1995 ~ 1998 model year vehicles, and in 1999 model year vehicles with Vehicle Identification Numbers prior to the VIN list shown above.

NOTE: These synchronizers and their component parts are not interchangeable with former part numbers for the 3rd ~ 4th and 5th ~ 6th gear synchronizers. All parts listed in the cell chart must be used as a set.

These 3rd ~ 4th and 5th ~ 6th gear synchronizers have been incorporated into service replacement transmission assemblies, part number 32020-Z3861 for UD1800HD ~ UD2300 and part number 32020-Z3160 for UD2600 ~ UD3000, manufactured after April, 1998. The manufacture date of the service replacement transmission assembly can be determined by the serial number stamped on top of the transmission shift cover.

		Date Code	
K 8 5 0 8	8	D	0 1 9
<u>Serial Number</u>	Year	Month	
0 = 2000	A = Jan		
9 = 1999	B = Feb		
8 = 1998	C = Mar		
7 = 1997	D = Apr		
6 = 1998	E = May		
	F = Jun		
	G = Jul		

When installing these 3rd ~ 4th and 5th ~ 6th gear synchronizer sets in:

- (a). 1995 ~ 1998 model year vehicles,
- (b). 1999 model year vehicles with Vehicle Identification Numbers prior to the VIN list provided, or
- (c). when replacing the complete transmission with a service replacement assembly with a manufacture date after April, 1998, the transmission shift cover must be stamped with the letters TR-14. This will indicate to future service technicians and parts departments that the unit already contains these current 3rd ~ 4th and 5th ~ 6th gear synchronizers.

Stamp the transmission shift cover between the shift cover bolt holes on the front left side as shown below.

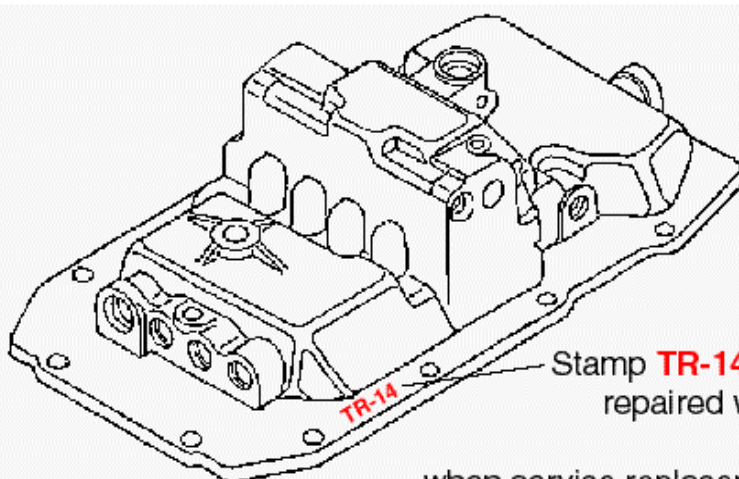

Stamp **TR-14** at this location on transmissions repaired with the new synchronizer sets
OR
when service replacement transmission assemblies are installed

PARTS NOTICE

The part numbers for the component parts of the current 3rd ~ 4th and 5th ~ 6th gear synchronizers are shown below. Synchronizer replacements in 1995 ~ 1998 model year vehicles or 1999 model year vehicles prior to the VIN list shown above should be serviced using these part numbers.

NOTE: The current synchronizer and its component parts are not interchangeable with former versions of the 3rd ~ 4th and 5th ~ 6th gear synchronizer. All parts must be replaced as a set.

REPLACE ALL PARTS AS A COMPLETE SET ONLY!

3rd - 4th SYNCHRONIZER SET KIT PART NUMBER K2605-Z5169 INCLUDES THE FOLLOWING COMPONENTS:		
PART NAME	PART NUMBER	QTY.
3rd GEAR	32261-Z5076	1
3rd – 4th HUB	32606-Z5112	1
3rd – 4th SYNCHRONIZER RING	32605-Z5169	2
3rd – 4th SYNCHRONIZER SPRING	32608-Z5063	2
3rd – 4th SYNCHRONIZER STRUT	32609-Z5007	3
3rd – 4th SLEEVE	32607-Z5100	1
4th GEAR	32277-Z5073	1

5th - 6th SYNCHRONIZER SET KIT PART NUMBER K2605-Z5170 INCLUDES THE FOLLOWING COMPONENTS:		
PART NAME	PART NUMBER	QTY.
5th – 6th HUB	32606-Z5068	1
5th – 6th SYNCHRONIZER RING	32605-Z5170	2
5th – 6th SYNCHRONIZER SPRING	32608-Z5064	2
5th – 6th SYNCHRONIZER STRUT	32609-Z5007	3
5th – 6th SLEEVE	32607-Z5101	1

**THE INFORMATION CONTAINED IN THIS BULLETIN SHOULD NOT BE INTERPRETED AS
THE BASIS FOR WARRANTY CLAIMS**